

SUBARU FORESTER



SUBARU

Confidence in Motion





THE ESSENCE OF **EXHILARATION.**

Handling. Reliability. Safety. Exhilaration. There are certain characteristics that make every Subaru, a Subaru. And you only have to slip behind the wheel once to fully appreciate them. Every vehicle in the range is powered by Subaru's world famous low-centre of gravity BOXER engine and permanent Symmetrical All-Wheel Drive (AWD) system. This unique set-up gives every Subaru the remarkable balance, stability and poise of a dedicated on-road vehicle combined with the traction, control and off-road agility of a full-blown 4x4. The Subaru Forester is the pioneering SUV in the range that makes full use of Subaru's unique capabilities and creates a benchmark for all other SUVs.





THE **PIONEERING** ADVENTURER.

A trail-breaking pioneer of the family crossover when first launched in 1997, the ultra-rugged Subaru Forester SUV has now evolved into an accomplished and capable expedition leader. Engineered to conquer ledges, rocks and other obstacles with ease, the Subaru Forester is more than ready to take on any challenge. Now in its fourth generation, the Subaru Forester still retains the engineering, reliability, performance and practicality that made the original such a success but with even greater capabilities. The addition of technological advances like X-Mode - a system that takes control of the engine, transmission, AWD and brakes to safely navigate through bad roads and slippery surfaces with maximum confidence, and Hill Descent Control - that takes care of speed and braking when going downhill while you concentrate on steering, has made driving the Subaru Forester easier and safer than ever. Of course, it goes without saying, the Subaru Forester is still practical and reliable. It is at home both on-and-off-road with a car full of kids bikes, buggies, camping gear and muddy dogs.





THE X FACTOR.

The second wind. It's that extra bit of strength summoned from within that helps you rise to the occasion and conquer the challenge. The Subaru Forester finds its inner strength with X-Mode. Activated with the push of a button, it gives the Subaru Forester that extra bit of capability you may need to take on adverse road and weather conditions.

1 | X-MODE^{*1} AND HILL DESCENT CONTROL^{*1}

"X" marks added capability for any driver, on any road. With a push of a button, X-Mode takes control of the engine, transmission, AWD, brakes and other components to safely navigate through bad roads and slippery surfaces for maximum confidence. For challenging descents, Hill Descent Control enhances confidence down the steepest of hills you'll encounter by providing constant, controlled momentum so the driver can focus more on steering the vehicle and less on braking.

2 | ENGINEERING THAT DOESN'T QUIT

The Subaru Forester was engineered to help you conquer obstacles. The larger the object, the larger the approach and departure angles needed to prevent damage to the front and rear bumpers. Optimised for both, the Subaru Forester's ground clearance maximises break-over angles, minimising your chances of being hung-up from underneath.

^{*1} Standard on 2.0i XE (Lineartronic), 2.0i XE PREMIUM (Lineartronic), 2.0D XC (Lineartronic), 2.0D XC PREMIUM (Lineartronic) and 2.0XT.
^{*2} Angle is 22-degrees for 2.0XT and Diesel models.

1



2

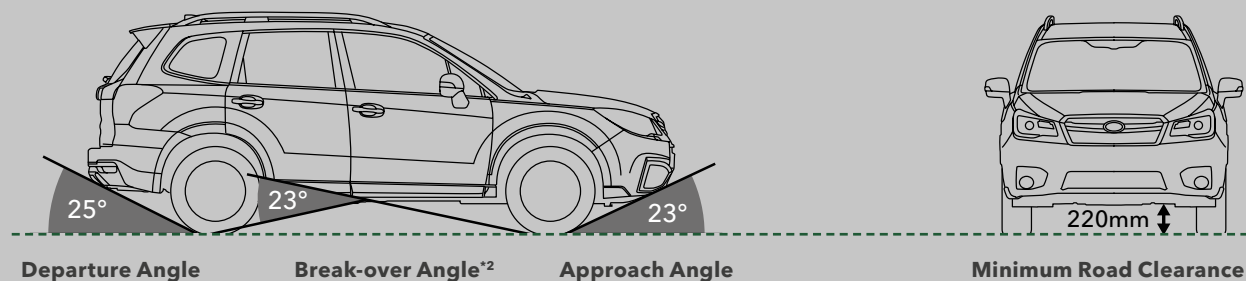

WELCOME TO **EXPEDITION BASE CAMP.**

Designed with an active lifestyle in mind, the redesigned interior of the Subaru Forester is the perfect place to start your adventures. Every feature of the Subaru Forester interior is thoughtfully placed to be right where you need it, when you need it. With high-quality materials and durable design, it's designed to make tasks simpler and driving more comfortable wherever your wanderlust takes you.





INFOTAINMENT: IN TOUCH. **IN CONTROL.** INFORMED.

Going on the road doesn't mean you have to leave it all behind. Stay grounded yet undistracted with technology that's intuitive and easy to use. The Subaru Forester keeps you connected and on course with infotainment, navigation and audio systems that you can either control with the touch of your fingertips or the sound of your voice. And with smartphone and iPhone³ connectivity, you're never without of your peers or playlists.

1 Instrument Cluster

The instrument panel of the Subaru Forester is designed to deliver information quickly and effortlessly. The tachometer and speedometer are clearly visible to help keep more focus on the road ahead.

4 Premium Audio System with Harman/Kardon Speakers⁶

The 8-speaker, 440W system was designed for ultimate sound performance. Two oval-shaped speakers are placed in the front doors and two speakers are installed at the rear doors.

2 High-grade Multifunction Display⁴

Located conveniently in the instrument panel, informative car vitals are displayed at the touch of a button. It also features advanced environmental performance and efficiency – even allowing you to compare the efficiency between different trips.

5 Voice Recognition² and Siri Eyes Free^{3*7}

Your Subaru Forester has more hands-free options than ever before, thanks to intuitive Voice Recognition² and Siri Eyes Free^{3*7} integration. Use Siri to link your compatible Apple³ product to your Subaru Forester, allowing you to make hands-free calls, play music, check emails and search the web.

3 Touchscreen Control

Use the touchscreen to easily manage your music, just as you would on your smartphone. Simply connect your smartphone through Bluetooth^{®15} or the USB port, and you can choose your music right on the touchscreen.

6 Steering wheel-mounted controls

Steering wheel-mounted controls place audio controls conveniently at your fingertips, and an available Bluetooth^{®15} hands-free system automatically links with your smartphone to help keep you focused on the road.

SUBARU STARLINK

Like a built-in smartphone for your car, having the SUBARU STARLINK¹ infotainment system lets you access Internet radio, entertaining apps and much more. Control it with the tablet-like 7-inch centre touchscreen, multifunction steering wheel controls, or one-shot Voice Recognition². If you can't find your favourite music, connect your iPhone³, smartphone or other mobile music device via the USB or standard AUX jack.



1

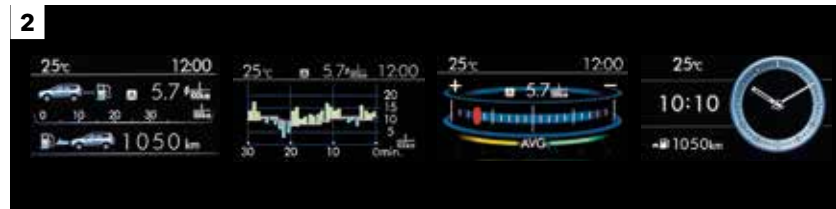

2



3



4



5



6

*1 Driver is always responsible for safe and attentive driving. Please refrain from operating the touchscreen while driving. Package communications fee may be charged depending on your area. Please check phone capability and availability of Subaru Starlink app.
 *2 Voice Recognition is compatible with select languages only and cannot accept all languages.
 *3 Apple, iPhone, iPod, Siri, and iTunes are registered trademarks of Apple Inc. App Store is a service mark of Apple Inc.
 *4 Standard on all models.
 *5 Bluetooth is a registered trademark of Bluetooth SIG, Inc. America.
 *6 Standard on 2.0i XE PREMIUM, 2.0D XC PREMIUM and 2.0XT.
 *7 Siri-compatible Apple product (iPhone, iPad, iPod touch, etc.) required.

EVERYTHING FOR OUTDOORS. **INDOORS.**

Camping. Canoeing. Climbing. Wherever you get your adrenaline hit, the Subaru Forester is more than able to keep up. From planned holidays to spontaneous hiking expeditions, the Subaru Forester has the capacity for any adventure. The wide cargo area can accommodate four large suitcases and even the bulkiest adventure gear, whilst a power rear gate, wider door openings and lower side sills help you load and unload with ease. For longer items, the rear seats fold flat in a 60/40 split.





NO ORDINARY ENGINE. NO ORDINARY SUV.

Few other SUVs drive with the level of confidence and responsiveness of the Subaru Forester and the main reason for this lies beneath the surface – the SUBARU BOXER engine. Its horizontally opposed configuration places the pistons 180 degrees apart for a lower, flatter profile than other engine types. This gives the engine, and therefore the overall vehicle, a lower centre of gravity and better sense of balance. Further, the pistons' opposing movements inherently counteract each other, naturally helping to reduce vibration.



BOXER DIESEL 2.0D XC & 2.0D XC PREMIUM

2.0-LITRE DOHC SUBARU BOXER DIESEL

MAX OUTPUT:
147 PS/3,600 rpm
MAX TORQUE:
350 Nm/1,600-2,400 rpm
FUEL CONSUMPTION:
46.3 mpg (Lineartronic)*1,
49.6 mpg (6MT)*1
CO₂ EMISSIONS:
158 g/km² (Lineartronic),
148 g/km² (6MT)

2.0XT

2.0-LITRE DOHC TURBO SUBARU BOXER

MAX OUTPUT:
241 PS/5,600 rpm
MAX TORQUE:
350 Nm/2,400-3,600 rpm
FUEL CONSUMPTION:
33.2 mpg*1
CO₂ EMISSIONS:
197 g/km²

2.0i XE & 2.0i XE PREMIUM

2.0-LITRE DOHC SUBARU BOXER

MAX OUTPUT:
150 PS/6,200 rpm
MAX TORQUE:
198 Nm/4,200 rpm
FUEL CONSUMPTION:
43.5 mpg (Lineartronic)*1,
40.9 mpg (6MT)*1
CO₂ EMISSIONS:
150 g/km² (Lineartronic),
160g/km² (6MT)

Increased Stability

Because the engine block has a flatter profile and sits lower in the chassis, the overall vehicle is more stably balanced and resistant to side-to-side motion than other designs.

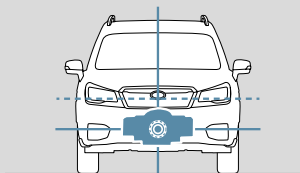

Long-lasting Performance

The engine's flat design is inherently rigid and self-balancing to achieve durability and reliable performance, generating less vibration than V-type or in-line engines in the same class.

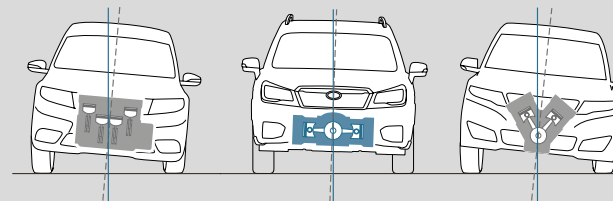

*1 MPG figures are official EU test figures for comparative purposes and may not reflect real driving results.

*2 Fuel consumption and CO₂ emissions: According to EC715/2007-2015/45/W.

SYMMETRICAL ALL-WHEEL DRIVE

Control leads to confidence, and stability creates an agility that excites in the Subaru Forester. Subaru vehicles are gifted at inspiring confidence behind the wheel, thanks to the inherently stable design of Symmetrical AWD paired with the uniquely balanced SUBARU BOXER engine. This system delivers power to all four wheels at all times for enhanced control on all roads and in poor conditions. It has excellent side-to-side balance and handling precision, thanks to its main components being aligned longitudinally, whilst its low centre of gravity creates an especially engaging and responsive drive. The unique advantages of Symmetrical AWD make for exceptionally rewarding handling and empower you to better avoid danger.

SUSPENSION

For responsive handling and capability over a variety of surfaces and conditions, the Subaru Forester is equipped with advanced front and rear suspension. With spring rates and dampening dialled in for smooth surfaces as well as rough, the Subaru Forester is a true multi-purpose vehicle. For Direct Injection Turbo (DIT) models, the front suspension features friction-control oil seals, guide bushings, hydraulic fluid on the struts, and optimised suspension tuning - all working together to help smooth vibrations and decrease body roll. Also for the DIT model, the rear support sub-frame provides a more rigid base to mount the rear suspension, for a more controlled ride and more responsive steering.

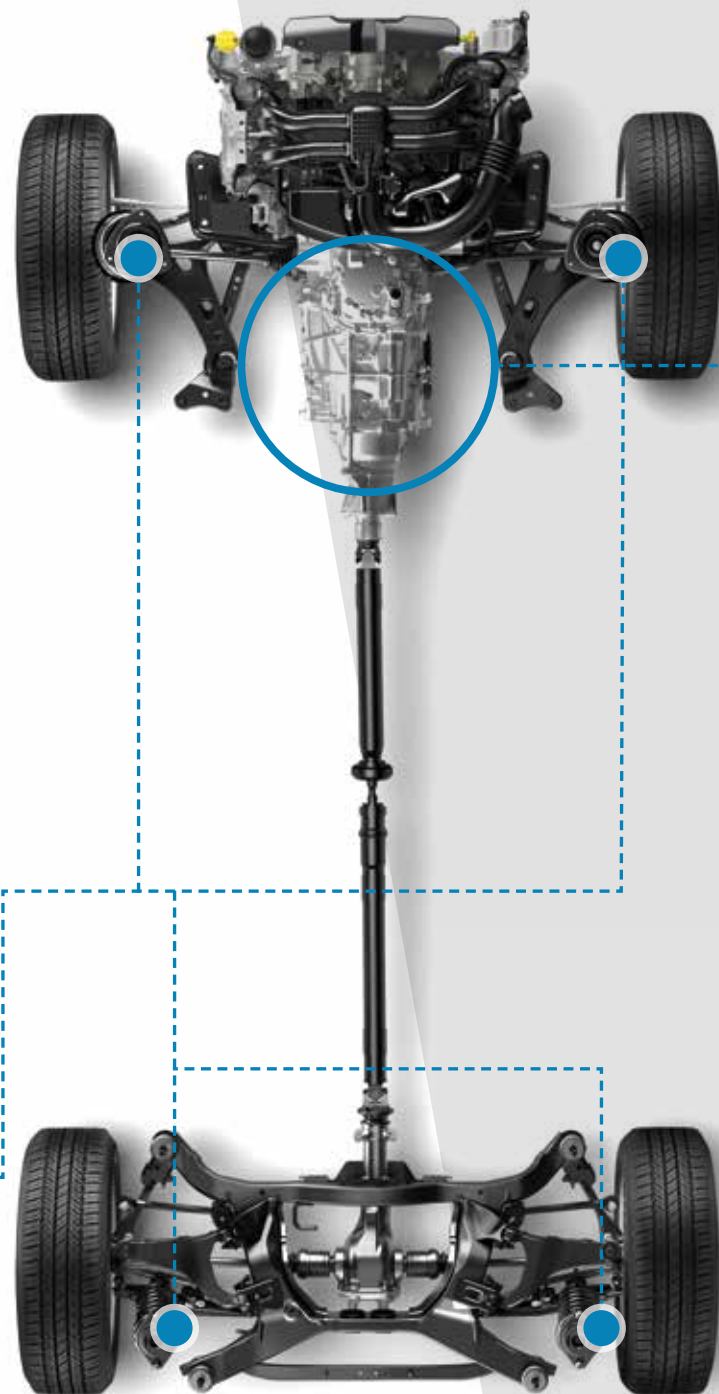

SYMMETRICAL ALL-WHEEL DRIVE. THE KEY TO A REWARDING DRIVE.

LINEARTRONIC + ACTIVE TORQUE SPLIT AWD

For instant, seamless response to changing conditions, the Lineartronic Continuously Variable Transmission (CVT) uses a chain instead of a belt - allowing a greater span of overall ratios for improved performance and efficiency as well as a faster response to throttle input. It's longitudinally paired with an active torque-split AWD system that responds to traction conditions, the transmission and driver inputs by continuously controlling the torque distribution front to rear.

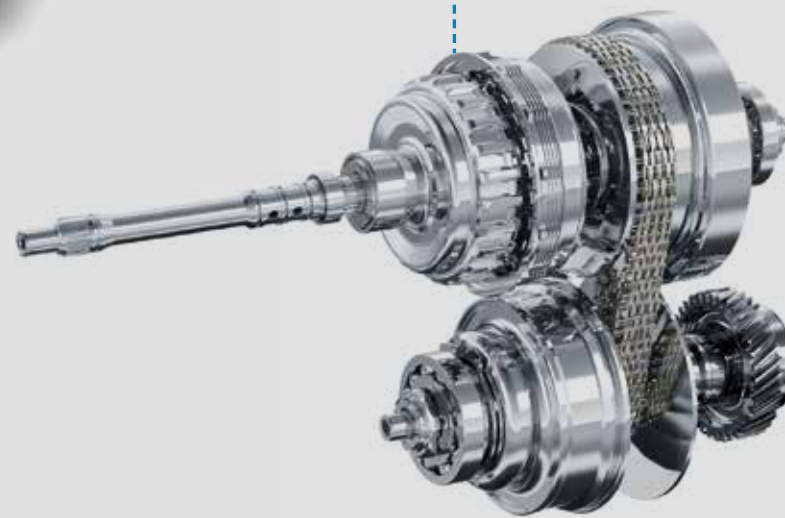

SI-DRIVE^{*1}

Subaru Intelligent Drive (SI-DRIVE) can adjust the responsiveness of its drivetrain to support your driving style, road conditions or any driving state at your immediate request. Quickly re-map the throttle response and automatic-transmission shifting behaviour to ensure that you always have the best performance for any circumstance.

[S#] Sport Sharp Mode^{*2}

With the focus on response, Sport Sharp mode drives the engine to its maximum potential. In this mode, the engine responds directly to the accelerator for a more powerful delivery when accelerating. Use the paddle shifters in Sport Sharp mode and you take more control of engine performance with eight gear ratios - like an 8-speed transmission - for truly spirited driving.

[S] Sport Mode

Sport mode delivers smooth engine performance at any driving speed. You'll immediately feel a linear response that brings to life the refined, torque-rich response.

[I] Intelligent Mode

SI-DRIVE activates Intelligent mode for immediate driving response and environmental responsibility. Throttle mapping balances smoothness and efficiency for an enhanced level of control.

^{*1} Standard on 2.0i XE, 2.0i XE PREMIUM and 2.0XT.

^{*2} 3-mode SI-DRIVE (Sport Sharp mode, Sport Mode and Intelligent mode) is available only on 2.0XT. Other models are available with 2-mode SI-DRIVE (Sport mode and Intelligent mode).



YOUR SAFETY. IN OUR HANDS.

Subaru takes safety seriously. And the capabilities of the Subaru Forester reflect this. To help you avoid accidents and protect you when they can't be avoided, the Subaru Forester is equipped with both active and passive safety features. Subaru Active Safety helps you circumvent trouble and avoid incidents before they happen with predictable handling, precise control, excellent visibility and advanced technologies. Passive Safety features are there to help protect you if the unthinkable does occur and include systematically placed airbags, whiplash-reducing front seats, retracting pedals and 3-point seatbelts.

PASSIVE SAFETY.

Ring-shaped Reinforcement Frame

The Ring-shaped Reinforcement Frame strengthens the passenger cabin's roof, doors, pillars and floor. This design helps divert and dissipate impact energy away from the occupants in a collision by use of highstrength materials and strategic placements. Whilst making it stronger with increased torsional rigidity, the overall frame is still lightweight.

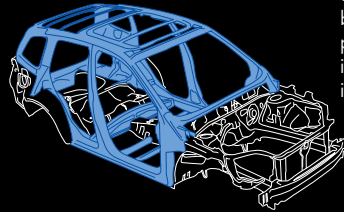

Seats, Seatbelts and SRS* Airbags

Standard on Subaru Forester are front SRS* airbags, plus front-side, curtain SRS* airbags and knee SRS* airbags. Height-adjustable front seatbelts feature pretensioners to hold passengers firmly in place and load limiters that ease peak forces to the chest. In a rear collision, front seats utilise rigid frames, firm headrests and such details as energy-absorbing mounting of the inner seat springs, all to help reduce the chance of whiplash.

Pedestrian Protection

Shock-absorbing space within the vehicle helps reduce pedestrian injury, as does an energy-absorbing front bumper with a specially designed area around the windshield wipers. And in order to provide protection in the head zone, a split-type construction in the front has been implemented.

5-Star Euro NCAP Rating

The Subaru Forester has been awarded the maximum five-star safety rating in the latest round of Euro NCAP (European New Car Assessment Programme) safety performance tests.

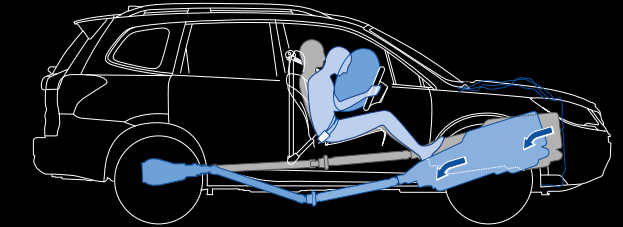

Cabin-protecting layout

Every Subaru goes above and beyond common practice when it comes to your safety. In the event of a head-on collision, your Forester's SUBARU BOXER engine and gearbox are designed to avoid rushing into the cabin for your protection.



ACTIVE SAFETY.

Visibility

With a commanding perspective and front and rear visibility at the top of its class, the Subaru Forester keeps the driver aware and at ease on the narrow roads and tight spaces. Blind spots are kept to a minimum with well-positioned A-pillars and integrated partition windows. The side mirrors have also been placed onto the door panels, creating a remarkably open field of view.

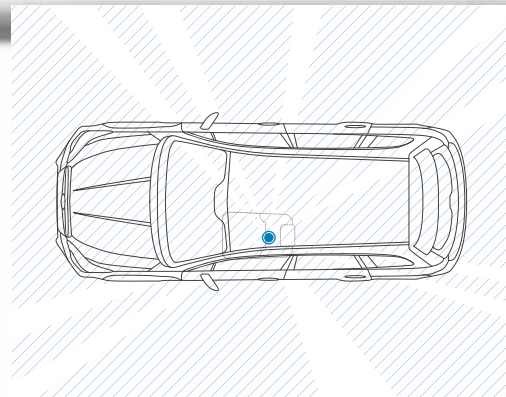

Braking System

The standard 4-wheel disc braking system is enhanced by Antilock Braking System (ABS) with Electronic Brake-force Distribution, to help redistribute braking power where you need it among all four wheels, and also Brake Assist and Brake Override for control in emergency braking situations. There's also Auto Vehicle Hold, which helps prevent rollback when starting from a stop on any slope. The DIT model adds larger 17-inch ventilated discs in front and 16-inch ventilated discs for the rear, for even better braking performance.

Vehicle Dynamics Control System

Vehicle Dynamics Control System monitors and analyses if the vehicle is following the driver's intended course via an array of sensors. If a tyre slips or a high speed turn causes the vehicle off its intended path, the AWD torque distribution, engine output and brakes at each wheel are adjusted to assist in keeping the vehicle on course.

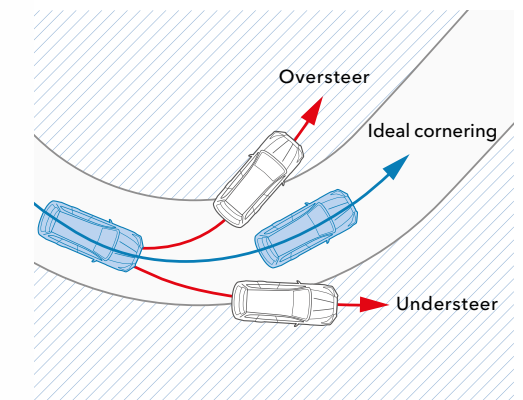

*SRS: Supplemental Restraint System. Effective when used in conjunction with seatbelts.

EXTERIOR COLOUR OPTIONS.



2.0i XE, 2.0i XE PREMIUM, 2.0D XC and 2.0D XC PREMIUM:



Quartz Blue Pearl



Ice Silver Metallic



Sepia Bronze Metallic



Crystal White Pearl



Venetian Red

EXTERIOR COLOUR OPTIONS.



2.0XT:



Black Silica



Crystal White Pearl



Dark Grey Metallic



Venetian Red

MODEL FEATURES.



2.0i XE AND 2.0D XC (6MT/LINEARTRONIC)

Exterior

Auto on/off headlamps
 HID headlamps with auto levelizer
 Pop-up type headlamp washers
 Front fog lamps
 Rear fog lamp
 Front head lights integrated daytime running light
 Over-folding door mirrors
 UV protection glass: Windshield and front side windows
 Designed blade, variable intermittent windshield wipers
 Intermittent rear window wiper
 Sports grill (Except on 2.0i XE and 2.0i XE PREMIUM)
 17-inch aluminium alloy wheels (Silver)
 Power sliding, large glass sunroof
 Roofrails
 Roof spoiler
 Shark-fin antenna

Seating/Trims

Leather wrapped steering wheel and gearshift knob
 Front seat heaters
 Manual seat lifter (driver's seat only)
 8-way power adjustable driver's seat
 Power seat with Seat Memory (Except on 2.0i XE)
 60/40 split folding rear seats
 One-touch folding and reclining rear seats
 Seat back pocket

Comfort/Convenience

Power windows¹
 Remote Control Key System
 One-touch lane changer
 Map lamps
 Luggage space lamp
 Vanity mirrors with lids (for driver and front passenger)
 Over head console box
 Centre console box
 Centre console box
 2 front cup holders (in the centre console)
 2 rear cup holders (in rear seat centre armrest)
 Door pockets with bottle holders (on all side doors)
 Interior fuel lid lock release
 Three 12-volt power outlets (in the instrument panel, centre console box and luggage space)
 4 cargo hooks
 Luggage hooks
 Retractable cargo cover

Climate control

Dual-zone automatic air-conditioning system with anti-dust filter
 Heater ducts for rear passengers
 Windshield wiper de-icer
 Automatic rain-sensing windshield wipers
 Heated door mirrors
 Front and side defrosters
 Electric rear window defogger with timer

Entertainment

7.0 Display SUBARU STARLINK infotainment system with Premium audio system²: 1CD and 6 speakers
 Voice Recognition system (Command speech and One shot)
 Steering wheel mounted audio remote control switches
 Bluetooth³-compatible hands-free system
 Dual USB ports and auxiliary audio input jack
 Rear Vision Camera System

Control/Instruments

High-grade type Multi Function Display⁴
 Tilt-adjustable/telescopic steering wheel
 Paddle shift (Lineartronic models only)
 Cruise control

Drivability

SI-Drive (SUBARU Intelligent Drive⁵) (2.0i XE only)
 Auto start-stop system with OFF switch (2.0i XE only)
 X-MODE (Lineartronic models only)
 Hill Descent Control (Lineartronic models only)
 Hill Start Assist
 Vehicle Dynamics Control System (VDC) with OFF switch
 Towing VDC
 Self-levelizer (load-compensating rear struts)

Safety

Daytime running lights
 Front SRS⁶ airbags
 Front side SRS⁶ airbags (for driver and front passenger)
 Curtain SRS⁶ airbags (front and rear, both sides)
 Knee SRS⁶ airbag
 Side-door reinforcement beams (front and rear, both sides)
 Steering column support beam
 Whiplash reducing front seats
 Rear seat headrests for 3 seating positions
 Seatbelt indicator (for driver and all passengers)
 Front seatbelts with pretensioners and load limiters
 Height adjustable seatbelt anchors (for driver and front passenger)
 Rear 3-point seatbelts for 3 seating positions
 Safety pedal system
 4-sensor/4-channel ABS with Electronic Brake-force Distribution
 Brake assist system
 Brake Override
 ISO-FIX adapted child seat anchors (with tether anchors)
 Child-proof rear door locking (both sides)
 Thatcham Category 1 security system with engine immobiliser



PREMIUM MODELS (6MT/LINEARTRONIC)

Additional features to 2.0i XE and 2.0D XC:

Exterior

Sports grill (Except on 2.0i XE PREMIUM)

Seating/Trims

Leather seats
 Power seat with Seat Memory

Comfort/Convenience

Keyless Access (touch-sensor type) and Push Button Start System
 Power rear gate (Except on 2.0i XE PREMIUM)

Entertainment

SUBARU STARLINK infotainment system with SD card type navigation and audio system²: 1-CD and 6 speakers

Control/Instruments

Paddle shift (Lineartronic models only)

Drivability

SI-Drive (SUBARU Intelligent Drive⁵) (XE PREMIUM only)
 Auto start-stop system with OFF switch (Except on 2.0D XC PREMIUM)
 X-MODE (Lineartronic models only)
 Hill Descent Control (Lineartronic models only)
 Self-levelizer (load-compensating rear struts)

2.0i XT (LINEARTRONIC)

Additional features to 2.0i XE, 2.0D XC, and PREMIUM models:

Exterior

Front sports bumper
 Privacy glass for rear doors, rear quarters and rear window
 18-inch aluminium alloy wheels (Silver/Black)
 Twin-tail muffler

Control/Instruments

Alloy pedals



*1 Driver's side front window has auto up/down function with pinch protection.

*2 Equipped with 7-inch VGA centre display.

*3 Bluetooth is a registered trademark of Bluetooth SIG, Inc. America.

*4 4.3-inch LCD screen displays. It shows: Fuel Economy screen, Eco-evaluation screen, Active safety, Clock/Outside temperature and Self check etc.

*5 3-MODE SI-Drive (Intelligent mode, Sport mode, Sport Sharp mode) is available only on 2.0XT. Other models are available with 2-MODE SI-Drive (Intelligent mode, Sport mode).

*6 SRS: Supplemental Restraint System. Must be used in conjunction with seatbelts.

Standard and optional features, model lineup may vary according to market.

INTERIOR OPTIONS.

PREMIUM MODELS AND XT

LEATHER BLACK



Seat Trim



Seat Backing

2.0i XE and 2.0D XC

FABRIC BLACK



Seat Trim



Seat Backing

FEATURES.



1 Steering Responsive Headlights (SRH)

When rounding a corner at night, the illumination direction of the headlights move left or right according to the steering wheel to ensure visibility.

2 18-inch Aluminium-alloy Wheels*¹

The 2.0XT is equipped with multi-spoke 18-inch aluminium-alloy wheels and 225/55R18 tyres.

3 Automatic Rain-sensing Windshield Wipers

Available automatic windshield wipers detect rainfall on the glass and adjust their wiping intervals and speed accordingly.

4 Headlamp Washers

Pop-up washers use a high pressure spray to help keep the headlamps at their peak performance in poor weather.

5 Fog Lamps

Multi-reflector fog lamps also serve as daytime running lights, and emit a wide, flat beam that reflects less glare in fog, for added safety.

6 Power Glass Sunroof

The large, internally sliding sunroof with manual sunshade delivers a panoramic view and fresh breezes for front and rear passengers.

7 Keyless Access and Push-button Start*²

Your key fob gives you easy keyless access. Simply grip the door handles to unlock them and start the engine with a button. Even without your fob, a 5-digit PIN code can unlock the doors.

8 4-way Steering Column

To help set your optimum driving position, the adjustable steering wheel tilts up-down and telescopes in-out.

9 8-way Power Adjustable Driver's Seat

This allows you to find a comfortable seating position by 8-way power adjustment. In models with leather interior, a 2-seat position memory function has been added.

10 Three 12V Power Outlets

Auxiliary power is at your fingertips with a 12-volt power outlet located in the centre console, centre console box and cargo space.

11 One-touch Folding Switches

Switches in the cargo area automatically fold each of the 60/40 split rear seatbacks, expanding the luggage space with remarkable ease.

12 Dual-zone Automatic Air-conditioning System

This feature conveniently helps keep the temperature inside where you want it. It also allows the driver and front passenger to set different temperatures.

*1 Standard on 2.0XT.

*2 Available on 2.0XT and 2.0D XC PREMIUM.



SUBARU

Confidence in Motion

Web Homepage

Visit our UK homepage for complete information and news about Subaru and our vehicles.

subaru.co.uk



YouTube

Subscribe to our channel to see all the latest videos and join the conversation.

youtube.com/subaruuk



Facebook

Stay connected to our diverse Subaru community and be the first to hear the latest news directly from our facebook page. facebook.com/OfficialSubaruUK



Twitter

Stay connected to our diverse Subaru community and be the first to hear the latest news directly from our twitter page. twitter.com/subaruuk



Instagram

Join us on Instagram as we showcase our latest models.

instagram.com/subaruuk



Pinterest

Join us on Pinterest as we showcase our latest models.

pinterest.com/subaruuk

PERSONALISE YOUR RIDE.

Whilst every Subaru Forester comes generously equipped, Subaru accessories are the perfect way to tailor your Subaru to your life and your style. Whether you want to add convenience, enhance functionality, or personalise your Subaru Forester's appearance, Subaru accessories are designed to provide the same fit and quality as your Subaru vehicle. For more details, ask for the accessory brochure or visit your nearest Subaru retailer.

Please check with your local Subaru dealer for accessory applicability.



Front Resin Underguard



Side Resin Underguard



Rear Resin Underguard



Cargo Step Panel (Resin)



Fender Flare



Engine Underguard Aluminium

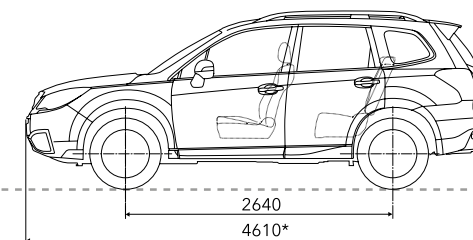
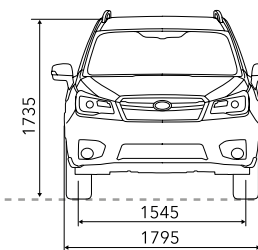

DIMENSIONS

Dimensions are measured in accordance with standard measurement of Fuji Heavy Industries Ltd.

*2.0i XE, 2.0i XE PREMIUM, 2.0D XC and 2.0D XC PREMIUM

Fuji Heavy Industries Ltd. reserves the right to alter specifications and equipment without notice. Details of specifications, equipment, colour availability and the accessory lineup are subject to suit local conditions and requirements. Please inquire at your local dealer for details of any changes that might be required for your area.

SPECIFICATIONS

Item	SUBARU FORESTER					
	Symmetrical AWD (All-Wheel Drive)					
	2.0i XE		2.0i XE PREMIUM		2.0XT	
	6MT	Lineartronic	6MT	Lineartronic	Lineartronic	
ENGINE						
Type	Horizontally-opposed, 4-cylinder, 4-stroke, petrol engine					Horizontally-opposed, 4-cylinder, 4-stroke, turbocharged, petrol engine
	DOHC 16-valve					
Bore / Stroke	mm 84.0×90.0				86.0×86.0	
Capacity	cc 1,995				1,998	
Compression ratio	10.5				10.6	
Fuel system	Multi-Point Sequential Injection (Port injection)				Gasoline direct injection	
Fuel tank capacity	lit. 60					
PERFORMANCE						
Max. output (DIN)	PS (kW)/rpm 150 (110)/6,200		150 (110)/6,200		241 (177)/5,600	
Max. torque (DIN)	Nm (kgfm)/rpm 198 (20.2)/4,200		198 (20.2)/4,200		350 (35.7)/2,400-3,600	
Max. speed	mph 118		119		137	
Acceleration (0-62 mph)	sec. 10.6		11.8		7.5	
Fuel consumption ^{*1}	Urban mpg (lit./100 km)	33.2 (8.5)	34.9 (8.1)	33.2 (8.5)	34.9 (8.1)	25.2 (11.2)
	Extra-urban mpg (lit./100 km)	47.1 (6.0)	51.4 (5.5)	47.1 (6.0)	51.4 (5.5)	40.4 (7.0)
	Combined mpg (lit./100 km)	40.9 (6.9)	43.5 (6.5)	40.9 (6.9)	43.5 (6.5)	33.2 (8.5)
CO ₂ emissions ^{*2}	Urban g/km	197	188	197	189	195
	Extra-urban g/km	140	129	140	129	161
	Combined g/km	160	150	160	150	197
DRIVETRAIN						
AWD type	Centre differential gear coupled with viscous LSD		Active Torque Split AWD system	Centre differential gear coupled with viscous LSD	Active Torque Split AWD system	
DIMENSIONS & WEIGHT						
Overall length	mm 4610					4595
Overall width	mm 1,795					
Overall height	mm 1,735					
Wheelbase	mm 2,640					
Track	Front	mm 1,545				
	Rear	mm 1,555				
Minimum road clearance (at kerb weight)	mm 220					
Cargo volume ^{*3}	lit. 1,592/1,573 ^{*4}					
Seating capacity	persons 5					
Kerb weight	kg 1,488	1,519	1,491	1,528	1,624	
Towing capacity (braked)	kg 1,800	2,000	1,800	2,000		
TRANS-AXLE						
Gear ratio	D range (S#)	-	3.581-0.570	-	3.581-0.570	3.505-0.544 (3.505)
	1st (S#)	3.818	3.581	3.818	3.581	3.505 (3.505)
	2nd (S#)	1.947	2.262	1.947	2.262	2.238 (2.522)
	3rd (S#)	1.296	1.658	1.296	1.658	1.641 (1.940)
	4th (S#)	1.029	1.208	1.029	1.208	1.194 (1.527)
	5th (S#)	0.825	0.885	0.825	0.885	0.880 (1.201)
	6th (S#)	0.738	0.618	0.738	0.618	0.611 (0.976)
	7th (S#)	-	-	-	-	-(0.800)
	8th (S#)	-	-	-	-	-(0.664)
Reverse (S#)	4.072	3.667	4.072	3.667	2.345	
Final drive axle ratio	4.444	3.900	4.444	3.900	4.111	
CHASSIS						
Steering	Pinion-assist type electric power steering system					
Suspension	Front	MacPherson strut type				
4-wheel independent	Rear	Double wishbone type				
Minimum turning circle at tyre (radius)	m 5.3					
Brakes	Front	Ventilated disc brakes				
	Rear	Solid disc brakes			Ventilated disc brakes	
Tyre / wheel size	225/60R17, 17×7"J			225/55R18, 18×7"J		

*1 MPG figures are EU test figures for comparative purposes and may not reflect real driving results.

*2 Fuel consumption and CO₂ emissions: According to EC 715/2007-136/2014W.

*3 Measured by VDA (V214).

*4 Measurement with sunroof.

Item	SUBARU FORESTER					
	Symmetrical AWD (All-Wheel Drive)					
	2.0D XC		2.0D XC PREMIUM			
	6MT	Lineartronic	6MT	Lineartronic		
ENGINE						
Type	Horizontally-opposed, 4-cylinder, 4-stroke, turbocharged, diesel engine					
	DOHC 16-valve					
Bore / Stroke	mm 86.0×86.0					
Capacity	cc 1,998					
Compression ratio	15.2					
Fuel system	Common rail (Self ignition)					
Fuel tank capacity	lit. 60					
PERFORMANCE						
Max. output (DIN)	PS (kW)/rpm 147 (108)/3,600					
Max. torque (DIN)	Nm (kgfm)/rpm 350 (35.7)/1,600-2,400					
Max. speed	mph 118		117		118	
Acceleration (0-100 km/h)	sec. 9.9					
Fuel consumption ^{*1}	Urban mpg (lit./100 km)	39.8 (7.1)	38.7 (7.3)	39.8 (7.1)	38.7 (7.3)	
	Extra-urban mpg (lit./100 km)	57.6 (4.9)	52.3 (5.4)	57.6 (4.9)	52.3 (5.4)	
	Combined mpg (lit./100 km)	49.6 (5.7)	46.3 (6.1)	49.6 (5.7)	46.3 (6.1)	
CO ₂ emissions ^{*2}	Urban g/km	183	190	189	195	
	Extra-urban g/km	128	140	128	140	
	Combined g/km	148	158	148	158	
DRIVETRAIN						
AWD type	Centre differential gear coupled with viscous LSD		Active Torque Split AWD system	Centre differential gear coupled with viscous LSD	Active Torque Split AWD system	
DIMENSIONS & WEIGHT						
Overall length	mm 4610					
Overall width	mm 1,795					
Overall height	mm 1,735					
Wheelbase	mm 2,640					
Track	Front	mm 1,545				
	Rear	mm 1,555				
Minimum road clearance (at kerb weight)	mm 220					
Cargo volume ^{*3}	lit. 1,592/1,573 ^{*4}					
Seating capacity	persons 5					
Kerb weight	kg 1,561	1,624	1,591	1,645		
Towing capacity (braked)	kg 2,000					
TRANS-AXLE						
Gear ratio	D range	-	3.505-0.544	-	3.505-0.544	
	1st	3.455	3.505	3.454	3.505	
	2nd	1.889	2.285	1.888	2.285	
	3rd	1.063	1.567	1.062	1.567	
	4th	0.789	1.179	0.785	1.179	
	5th	0.635	0.910	0.634	0.910	
	6th	0.558	0.723	0.557	0.723	
	7th	-	0.582	-	0.582	
	Reverse	3.636	2.345	3.636	2.345	
Final drive axle ratio	4.444	4.111	4.444	4.111		
CHASSIS						
Steering	Pinion-assist type electric power steering system					
Suspension	Front	MacPherson strut type				
4-wheel independent	Rear	Double wishbone type				
Minimum turning circle at tyre (radius)	m 5.3					
Brakes	Front	Ventilated disc brakes				
	Rear	Solid disc brakes			Ventilated disc brakes	
Tyre / wheel size	225/60R17, 17×7"J					

Vehicle kerb weight varies according to the types of optional equipment included. Specification data and model lineup may vary according to market.

The service interval for the Subaru Forester 2.0i XT is every 12 months/10,000 miles, whichever is sooner.

The Subaru Forester 2.0i XE, 2.0i XE Premium, 2.0D X, 2.0D XC and 2.0D XC Premium model service intervals are every 12 months/12,000 miles, whichever is sooner.

SPECIFICATIONS

Item	Symmetrical AWD (All-Wheel Drive)								
	2.0i XE	2.0i XE	2.0i XE PREMIUM	2.0i XE PREMIUM	2.0i XT	2.0D XC	2.0D XC	2.0D XC PREMIUM	2.0D XC PREMIUM
	6MT	Lineartronic	6MT	Lineartronic	6MT	Lineartronic	6MT	Lineartronic	
EXTERIOR									
Auto on/off headlamps	•	•	•	•	•	•	•	•	•
HID headlamps with auto levelizer	•	•	•	•	•	•	•	•	•
Pop-up type headlamp washers	•	•	•	•	•	•	•	•	•
Front fog lamps	•	•	•	•	•	•	•	•	•
Rear fog lamp	•	•	•	•	•	•	•	•	•
Front head lights integrated daytime running light	•	•	•	•	•	•	•	•	•
Power-folding door mirrors	•	•	•	•	•	•	•	•	•
UV protection glass: Windshield and front side windows	•	•	•	•	•	•	•	•	•
Privacy glass for rear doors, rear quarters and rear window	-	-	-	-	•	-	-	-	-
Designed blade, variable intermittent windshield wipers	•	•	•	•	•	•	•	•	•
Intermittent rear window wiper	•	•	•	•	•	•	•	•	•
Sports grill	-	-	-	-	•	-	-	-	-
Front sports bumper	-	-	-	-	•	-	-	-	-
17-inch aluminium alloy wheels (Silver)	•	•	•	•	-	•	•	•	•
18-inch aluminium alloy wheels (Silver/Black)	-	-	-	-	-	-	-	-	-
Power sliding, large glass sunroof	•	•	•	•	•	•	•	•	•
Roofrails	•	•	•	•	•	•	•	•	•
Roof spoiler	•	•	•	•	•	•	•	•	•
Shark-fin antenna	•	•	•	•	•	•	•	•	•
Twin-tail muffler	-	-	-	-	•	-	-	-	-
SEATING/TRIMS									
Leather wrapped steering wheel and gearshift knob	•	•	•	•	•	•	•	•	•
Leather seats	-	-	•	•	•	-	-	•	•
Front seat heaters	•	•	•	•	•	•	•	•	•
8-way power adjustable driver's seat	•	•	•	•	•	•	•	•	•
Power seat with Seat Memory	-	-	•	•	•	-	-	•	•
60/40 split folding rear seats	•	•	•	•	•	•	•	•	•
One-touch folding and reclining rear seats	•	•	•	•	•	•	•	•	•
Seat back pocket	•	•	•	•	•	•	•	•	•
COMFORT/CONVENIENCE									
Power windows ¹	•	•	•	•	•	•	•	•	•
Remote Control Key System	•	•	•	•	•	•	•	•	•
Keyless Access (touch-sensor type) and Push Button Start System	-	-	•	•	•	-	-	•	•
One-touch lane changer	•	•	•	•	•	•	•	•	•
Map lamps	•	•	•	•	•	•	•	•	•
Luggage space lamp	•	•	•	•	•	•	•	•	•
Vanity mirrors with lids (for driver and front passenger)	•	•	•	•	•	•	•	•	•
Over head console box	•	•	•	•	•	•	•	•	•
Centre tray	•	•	•	•	•	•	•	•	•
Centre console box	•	•	•	•	•	•	•	•	•
2 front cup holders (in the centre console)	•	•	•	•	•	•	•	•	•
2 rear cup holders (in rear seat centre armrest)	•	•	•	•	•	•	•	•	•
Door pockets with bottle holders (on all side doors)	•	•	•	•	•	•	•	•	•
Interior fuel lid lock release	•	•	•	•	•	•	•	•	•
Three 12-volt power outlets (in the instrument panel, centre console box and luggage space)	•	•	•	•	•	•	•	•	•
Power rear gate	-	-	•	•	•	-	-	•	•
4 cargo hooks	•	•	•	•	•	•	•	•	•
Luggage hooks	•	•	•	•	•	•	•	•	•
Retractable cargo cover	•	•	•	•	•	•	•	•	•
CLIMATE CONTROL									
Dual-zone automatic air-conditioning system with anti-dust filter	•	•	•	•	•	•	•	•	•
Heater ducts for rear passengers	•	•	•	•	•	•	•	•	•
Windshield wiper de-icer	•	•	•	•	•	•	•	•	•
Automatic rain-sensing windshield wipers	•	•	•	•	•	•	•	•	•
Heated door mirrors	•	•	•	•	•	•	•	•	•
Front and side defrosters	•	•	•	•	•	•	•	•	•
Electric rear window defogger with timer	•	•	•	•	•	•	•	•	•

Item	Symmetrical AWD (All-Wheel Drive)								
	2.0i XE	2.0i XE	2.0i XE PREMIUM	2.0i XE PREMIUM	2.0i XT	2.0D XC	2.0D XC	2.0D XC PREMIUM	2.0D XC PREMIUM
	6MT	Lineartronic	6MT	Lineartronic	6MT	Lineartronic	6MT	Lineartronic	
ENTERTAINMENT									
7.0 Display SUBARU STARLINK infotainment system with Premium audio system ² : 1CD and 6 speakers	•	•	-	-	-	•	•	-	-
SUBARU STARLINK infotainment system with SD card type navigation ² and audio system: 1-CD and 6 speakers	-	-	•	•	•	-	-	•	•
Voice recognition system (Command speech and One shot)	•	•	•	•	•	•	•	•	•
Steering wheel mounted audio remote control switches	•	•	•	•	•	•	•	•	•
Bluetooth ^{*3} -compatible hands-free system	•	•	•	•	•	•	•	•	•
Dual USB ports and auxiliary audio input jack	•	•	•	•	•	•	•	•	•
Rear Vision Camera System	•	•	•	•	•	•	•	•	•
CONTROL/INSTRUMENTS									
High-grade type Multi Function Display ⁴	•	•	•	•	•	•	•	•	•
Tilt-adjustable/telescopic steering wheel	•	•	•	•	•	•	•	•	•
Paddle shift	-	•	-	•	•	-	•	-	•
Cruise control	•	•	•	•	•	•	•	•	•
Alloy pedals	-	-	-	-	•	-	-	-	-
DRIVABILITY									
SI-Drive (SUBARU Intelligent Drive ⁵)	•	•	•	•	•	-	-	-	-
Auto start-stop system with OFF switch	•	•	•	•	-	-	-	-	-
X-MODE	-	•	-	•	•	-	•	-	•
Hill Descent Control	-	•	-	•	•	-	•	-	•
Hill Start Assist	•	•	•	•	•	•	•	•	•
Vehicle Dynamics Control System (VDC) with OFF switch	•	•	•	•	•	•	•	•	•
Towing VDC	•	•	•	•	•	•	•	•	•
Self-levelizer (load-compensating rear struts)	•	•	•	•	-	•	•	•	•
SAFETY									
Daytime running lights	•	•	•	•	•	•	•	•	•
Front SRS ^{*6} airbags	•	•	•	•	•	•	•	•	•
Front side SRS ^{*6} airbags (for driver and front passenger)	•	•	•	•	•	•	•	•	•
Curtain SRS ^{*6} airbags (front and rear, both sides)	•	•	•	•	•	•	•	•	•
Knee SRS ^{*6} airbag	•	•	•	•	•	•	•	•	•
Side-door reinforcement beams (front and rear, both sides)	•	•	•	•	•	•	•	•	•
Steering column support beam	•	•	•	•	•	•	•	•	•
Whiplash reducing front seats	•	•	•	•	•	•	•	•	•
Rear seat headrests for 3 seating positions	•	•	•	•	•	•	•	•	•
Seatbelt indicator (for driver and all passengers)	•	•	•	•	•	•	•	•	•
Front seatbelts with pretensioners and load limiters	•	•	•	•	•	•	•	•	•
Height adjustable seatbelt anchors (for driver and front passenger)	•	•	•	•	•	•	•	•	•
Rear 3-point seatbelts for 3 seating positions	•	•	•	•	•	•	•	•	•
Safety pedal system	•	•	•	•	•	•	•	•	•
4-sensor/4-channel ABS with Electronic Brake-force Distribution	•	•	•	•	•	•	•	•	•
Brake assist system	•	•	•	•	•	•	•	•	•
Brake Override	•	•	•	•	•	•	•	•	•
ISO-FIX adapted child seat anchors (with tether anchors)	•	•	•	•	•	•	•	•	•
Child-proof rear door locking (both sides)	•	•	•	•	•	•	•	•	•
Thatcham Category 1 security system with engine immobiliser	•	•	•	•	•	•	•	•	•

*1 Driver's side front window has auto up/down function with pinch protection.

*2 Equipped with 7-inch VGA centre display.

*3 Bluetooth is a registered trademark of Bluetooth SIG, Inc. America.

*4 4.3-inch LCD screen displays. It shows: Fuel Economy screen, Eco-evaluation screen, Active safety, Clock/Outside temperature and Self check etc.

*5 3-MODE SI-Drive (Intelligent mode, Sport mode, Sport Sharp mode) is available only on 2.0XT. Other models are available with 2-MODE SI-Drive (Intelligent mode, Sport mode).

*6 SRS: Supplemental Restraint System. Must be used in conjunction with seatbelts.

Standard and optional features, model lineup may vary according to market.



SUBARU

Confidence in Motion

5 YEAR
WARRANTY[†]

SYMMETRICAL AWD

The Subaru Forester is covered by a 5 Year/100,000 mile (whichever is sooner) Limited Warranty which comprises a standard 3 Year/60,000 mile (whichever is sooner) Manufacturer's Warranty (bumper to bumper, excluding clutch driven plate) and an Extended Warranty (applies to only powertrain) provided by the importer, Subaru (UK) Ltd, for up to a total of 5 Years or 100,000 miles (whichever occurs first). All vehicle bodywork is covered by a 12 Year Anti-Corrosion Warranty and paintwork is covered by a 3 Year Warranty. Added reassurance is provided by a comprehensive 3 Year Recovery and Assistance programme valid in the UK only. For general terms and conditions visit www.subaru.co.uk

Technical data and equipment based on the latest information available at the time of printing. Subaru (UK) Ltd reserves the right to make changes at any time, without notice, in colours, materials, design, prices, equipment and specifications and to discontinue models. Customers are advised to consult their Subaru dealer on the precise details of warranties/guarantees and vehicles available for sale. Models specified are strictly subject to availability. Owing to the limitations of printing processes, the colours reproduced may not exactly match product colours. The contents of this brochure are the copyright of Subaru (UK) Ltd and may not be copied or displayed for commercial purposes without the express permission of Subaru (UK) Ltd. © Subaru (UK) Ltd. E & O.E.

Subaru (UK) Ltd.

For details of your nearest Subaru dealer phone 08446 626612 or visit subaru.co.uk